

INSTALLATION INSTRUCTIONS ROTARY PHASE CONVERTERS

Notice

Before permanently installing this converter make sure it will operate your load!

You may temporarily connect your converter through the cover opening and satisfy yourself that your converter is adequate to operate your equipment before removing any knockouts or making permanent connections which would prevent return or exchange of this device.

Be sure to read all the instructions carefully before you attempt installation—we cannot be responsible for the failure of an incorrect installation.

Important—To the installing Licensed Electrician

1. The generated phase (T3) is red in color. **DO NOT** connect the generated phase (T3) to any single-phase loads, lights, or magnetic starter holding coils.
2. **DO NOT** connect a single-phase supply line to T3
3. This is a Delta 3-phase system. High voltage to ground (neutral) from T3 is perfectly normal and will not affect the normal operation of 3-phase equipment.

Warning: Disconnect power before servicing or connecting any equipment!

Electric shock can injure or kill you. This equipment should be installed in accordance with local and National Electric Codes.

1. Connect your rotary converter(s) and 3-phase equipment according to the appropriate wiring diagram following. Charts are provided which list wire, transformer and fusing recommendations for converters and 3-phase motors. Be sure all equipment is properly grounded per NEC Article 250. **Never connect a ground or neutral to T3** (the manufactured phase).
2. Magnetic controls or single-phase loads must always be energized by the single-phase lines L1 and L2. T3 should be isolated from any control circuits when possible. T3 is readily identified as the line with the highest voltage to ground.
3. Mount the converter anywhere practical in relation to the load, preferably as close to the service entrance as possible. A rubber mat or carpet under the converter will insure that any minimal vibration is not magnified, particularly when the rotary is mounted on a wooden floor or shelf.
4. The fused rotary knife switch shown in the installation diagrams will provide precise rotary protection and a positive means of turning each rotary on and off. **Do not turn your rotary on/off by the circuit breaker in your panel. Circuit breakers used to switch the rotary on/off will eventually fail, and may damage the breaker panel buss-bars as well.** Leave the breaker “on” and switch the converter with the knife switch or a magnetic motor starter.
5. Your converter should reach full speed in 1 to 3 seconds and run quietly. Line-Tamer (LT) models may take slightly longer to come up to speed. If the converter is noisy, draws high current, or does not start **immediately**, there is probably an error in the installation, which should then be reviewed.
6. Turn the converter “off” it will not be used for an extended period of time. Otherwise, let the rotary idle between loads. Turn the converter off overnight if it will not be in use.
7. Models with grease zerks: The converter was lubricated during the testing phase of production. For intermittent converter use: lubricate every 12 months with 2 or 3 pumps of high-temperature bearing grease. For 24-hour operation, lubricate every 6 months.
8. Voltages: The single-phase (input) voltage establishes the basis for the 3-phse output voltages (see voltage chart). Problems with voltage-sensitive machines are often caused by excessively-high line voltage rather than the converter.

(No-Load Voltages): Rotogen Converters					
Line Voltage	L1 to L2	220	230	240	250
Corresponding 3-Phase Voltages	L1 to T3	221	232	244	261
	L2 to T3	242	254	267	284

(No-Load Voltages): DIGI-Series Stabilized Voltage Converters					
Line Voltage	L1 to L2	220	230	240	250
Corresponding 3-Phase Voltages	L1 to T3	218	230	241	255
	L2 to T3	230	242	254	266

Remember: As loads are introduced, high 3-phase voltages go down. You will also note that an increase in the single-phase voltage results in a greater percentage increase in the no-load 3-phase voltages.

Line-to-Neutral voltages mean absolutely nothing in a 3-phase supply and may be ignored.

SEM/GWM Standard Rotary Converter Wiring and Service Data

Model/Rotary Frame Size	Minimum 1Ø Service 230v	Rotary Switch Fuses, 230v	Wire Size L1 & L2 Service to Each Rotary @ 50' or less		Minimum Utility Transformer kVA
	For 460v Operation Use ½ the Values Listed		230v	460v	
184	30 Amps	15 Amps	10 AWG	12 AWG	5
215	60	30	8	10	10
254	80	40	6	8	15
256	100	60	6	8	20
286	150	80	4	6	25
324	200	100	3	4	37.5
326	200	125	1	4	37.5
364	250	160	1/0	3	50
365	300	200	2/0	2	75
324x2	300	2-100 ea	3	4	75
364x2	400	2-160 ea	1/0	3	100

SEM/GWM Digi-Series Rotary Converter Wiring and Service Data

Model/Rotary Frame Size	Minimum 1Ø Service 230v	Rotary Switch Fuses, 230v	Wire Size L1 & L2 Service to Each Rotary @ 50' or less		Minimum Utility Transformer kVA
	For 460v Operation Use ½ the Values Listed		230v	460v	
184	30 Amps	30 Amps	8 AWG	12 AWG	5
215	60	60	6	10	10
254	100	80	4	8	15
256	100	100	3	6	20
286	200	125	2	4	25
324	200	150	1	4	37.5
326	200	175	1/0	3	37.5
364	200	200	2/0	3	50
365	400	250	3/0	1	75

Wire Sizing for 3-Phase Load Motors

230v Service Motor HP	Distance in Feet—Service to Motor	
	50'	100'
1 hp	14	14
2	14	12
3	12	10
5	10	8
7.5	10	8
10	8	6
15	6	4

230v Service Motor HP	Distance in Feet—Service to Motor	
	50'	100'
20	4	3
25	3	2
30	2	1
40	1	1/0
50	2/0	3/0
75	250 MCM	300 MCM
100	350	500

These wire sizes are for 230v operation. For 460 volts, use wire for a motor 1/2 the size you are operating.
(Ex. A 20 hp motor on a 460v system uses 10 hp, 230v wiring.)

Rotary Typical Connection

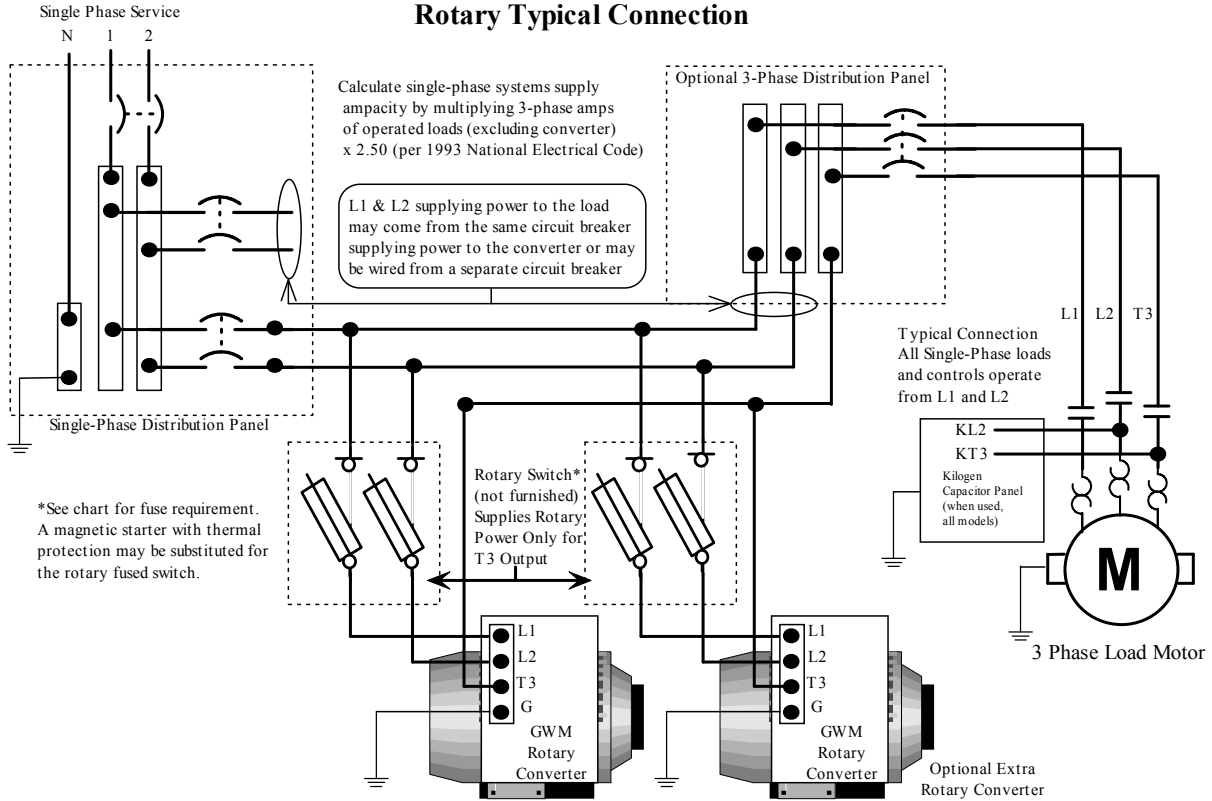

DIGI Typical Connection

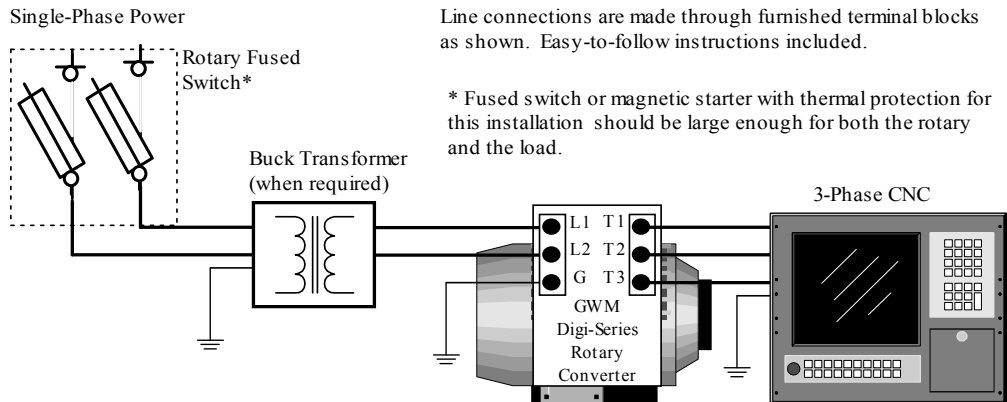

Connection for Multiple DIGI Rotary Converters

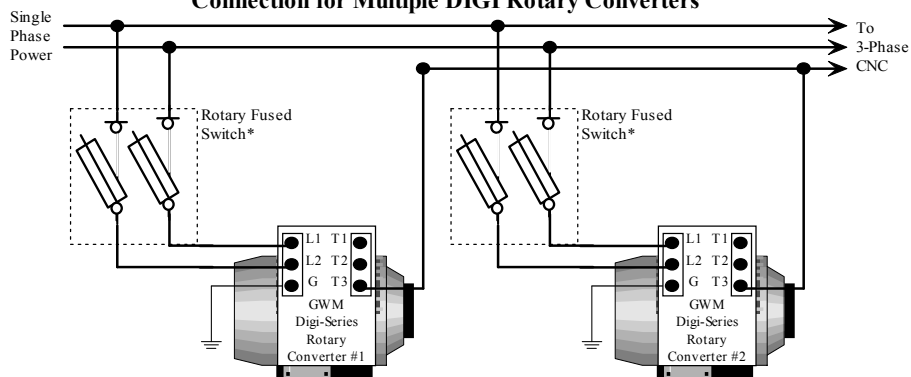

Use this method to parallel 2 or more converters. In this way the rotaries may be started one at a time to prevent line disturbance. Use L1 and L2 of the input block, T3 only of the output terminal block. A utility transformer of 2kVA per spindle HP of CNC is normally required for good machine operation.

* See chart for fuse requirements. A magnetic starter with thermal protection may be substituted for the rotary fused switch.

TROUBLESHOOTING GUIDE

Preliminary:

If you are trying to solve a problem that you believe is converter related, please carefully read the following:

If the unit in question is brand new, it was thoroughly tested at the factory, and there is an overwhelming degree of possibility that any operating problems is in the installation rather than the converter. So check your installation carefully, and review wire and transformer size to equipment. Electricity is fuel which may be burned as heat or to produce a magnetic field to run a motor. The converter you bought does not make fuel—it is a fuel distribution system. It can only work as well as the fuel you put into it. The wiring and transformers and fusing in you system are the fuel lines. If they are inadequate, our product will not correct it.

Remember that if the converter is running it is producing 3-phase power. The converter selected may not be adequate for your load, or your load may have a mechanical or electrical problem. If the converter and your load motors do not come right up to speed, there is something wrong. We are available to help solve the problem, but please re-read the instructions and check the Troubleshooting Guide first. We cannot be responsible for the failure of non-readers installations.

Problems and Solutions: The symbol “§” indicates most frequently used solutions.

Rotary will not start:

- A. Nothing happens with the switch on:
 - 1. § Blown fuse. Carbon tracks in fuse may fool a voltmeter. Use ohmmeter to check fuses.
 - 2. Open circuit (wire not connected).
 - 3. Breaker tripped.
- B. Rotary growls, turns over slowly with the switch on (single-phases):
 - 1. § Rotary starting under load. Turn off loads. The Rotary will not start under a load.
 - 2. § T3 shorted to ground. Disconnect T3 at converter and see if unit will the start.
 - 3. § Inadequate service supply produces line voltage drop at L1-L2. Check line voltage while trying to start Rotary (5 seconds maximum). Voltage below 200—Rotary will not start. Service, entrance, wire or utility transformer too small. Refer to chart for minimum service ampacity and utility transformer size.
 - 4. Pre-1995 models: Mechanical starting relay may be stuck. It is a small black relay with 3 spade wires. Smack it with something and see if the rotary starts. Check auxiliary contactor for welded contacts.
 - 5. Post-1995 models: Electronic starting relay operates a large starting contactor. Look for scorched parts, welded contacts, broken wire or a loose wire terminal. Call us for support.
 - 6. All non-LT models: Large start contactor may not be working. Remove cover from contactor to expose contacts. Contacts should close when converter is energized. This connects the black starting capacitors to the rotary circuit.
- C. § Rotary trips breaker or instantly blows fuses: Standard circuit breakers are not designed for motor inrush loads. Breakers feeding the fused knife switch (see installation diagram). The fuses knife switch provides precise protection for the rotary and provides a positive disconnect means. Failure to properly protect the rotary may shorten its life and void your warranty protection.
 - 1. § Fuses—Are fuses time-delay type? “One-time” fuses will blow instantly.
 - 2. § Line-tamer (LT) models: “run” contactor in main panel may have welded contacts. Open the box, remove contactor cover and inspect. DO NOT FILE CONTACTS! Pop stuck contacts apart and start rotary. This problem occurs during power outages, when load and converter are inadvertently shut off together, or if the single-phase voltage is inordinately high (243v+).

Load motor will not start:

- A. Load greater than converter is designed for. Check nameplate rating on converter. You may need to trade up or parallel another converter with your present unit for increased power, or add a “Hard-start” panel. Consult factory.
- B. § Load motor connected for 440v and running on 220v. Motor will only have 25% power at half the rated voltage.
- C. Mechanical problem. Belt too tight, bad bearing, etc. Take belts off and see if motor will start.
- D. § Wire size to motor too small. Refer to Motor Wire Size Chart.

Magnetic starter chatters on load machine:

- A. § Machine has magnetic coils or control transformer connected for higher voltage.
- B. § T3 is being used to power a magnetic coil or 1-phase control transformer. This may cause “telegraphing” of contacts. T3 is readily identified as having the highest voltage to neutral (ground)—190 to 230v. (on 230v system)

Rotary output voltage too high. Converter may also be overheating:

- A. High T3 to Neutral voltage, normal. This is a delta system. T3-N voltage is 1.73 times L1 to N voltage.
- B. High L1-T3 or L2-T3 voltage. No-load voltages will run 5-15% higher than L1-L2 on standard models. See voltage chart.
- C. § Units with an additional capacitor (Kilogen) panel: (Kilogen) capacitor panel is misconnected (See Installation Diagram). If the Kilogen is “hot” electrically when its load is not operating, converter damage may result.
- D. § Excessively high line voltage. The voltages produced by the converter are proportional to line voltage (see chart).
- E. § CNC/EDM or other voltage-sensitive equipment trips off or “alarms”. Single-phase voltage to the system may need to be “bucked” to align the system with the CNC. You may also disconnect 1 or more of the metal (run) capacitors to lower the 3-phase voltages, but first try to put T3 in a different position by advancing the leads coming into you CNC. Move lead #1 to position 2, lead #2 to position 3, and lead #3 to position 1. You can do this twice before your configuration returns to the original position.

Rotary output voltage too low with rotary at operating speed:

- A. Low no-load voltages: Indicates possibly defective motor run capacitors. Check for bulged or swollen capacitors, or fluid leaking from cells. Replace defective cells.
- B. § Low full-load voltage: Single-phase supply or wiring may be inadequate; or your rotary converter may be too small for your operated load. See “Load motor lack power” below.

Rotary noisy, may “howl” under no load, has magnetic whine. May vibrate:

- A. Rotary start circuit stuck. Pre-'95 models, check or smack small black start relay with 3 spade wires. Check start contactor for welded contacts. 1995-up models, visually inspect PC board (electronic start relay) for damage or loose connections, check start contactor to see if contacts are welded.
- B. § Kilogen Capacitor Panel misconnected: Refer to Installation Diagram and “Rotary output voltage too high” part C above.
- C. Line-Tamer (LT) model stuck in start mode: Check relays and contacts.

Load motors lack power:

- A. Rotary too small for loads. Kilogen panel may be added for moderate increase in motor power. Consult factory.
- B. Kilogen panel misconnected. See diagram. Misconnected capacitor panels will buck the converter and sap power.
- C. Motor may be connected for wrong voltage, or have a mechanical problem.
- D. § Single-phase supply voltage drop indicates an inadequate supply to converter and equipment.

Overloads on motors trip; Small motors heat up:

- A. Move overload to higher setting. High current on L2 and T3 indicates a rotary too large for the motor, or excessive capacitor current. If Kilogen (capacitor) panel equipped, panel should be disconnected or capacitors reduced in number to lower L2 to T3 voltage.
- B. High current on L1 only: May be ignored, or add capacitors (Kilogen) panel to increase L2 and T3 current and balance load.
- C. § Small motor may overheat on large converter. Run more motors or disconnect 1 or 2 metal run capacitors in rotary.

If you have reviewed your installation and exhausted all possibilities in the Trouble-Shooting Guide without finding a solution to your problem, you may contact the factory for further technical assistance. Any or all of the following information may be required for technical assistance:

1. Your complete converter model and serial number and any special accessories or controls your converter is equipped with;
2. The type and HP (or full-load amps) of the machine you are experiencing difficulty with;
3. Your single-phase service amps;
4. Your utility transformer kVA (stenciled on the side of pole-mount or pad-mount transformers);
5. If yours is a voltage problem, the single-phase line-to-line voltage and any other voltages in question, measured with a digital voltmeter.

SMITH ELECTRIC MOTORWORKS
GWM



225 W Hayden, Suite 100
Marceline MO 64658
Phone: 800-437-4273
(800-4-3-PHASE)

Toll: 660-376-9700
Fax: 660-376-9701
Email: sem@gwm4-3phase.com
www.gwm4-3phase.com